

ZCASE® M10 Bolt Down Single Fuses

Rated 32V

RoHS



Specifications

Voltage Rating:	32 V dc
Interrupting Rating:	2000 A @ 32 V dc
Recommended Environmental Temperature:	-40 °C to +125 °C
Terminals Material:	Tin-plated copper alloy
Housing Material:	PPA-GF33HS (UL 94 Flammability rating of HB)
Net Weight per Fuse:	22 g ± 10 %
Mounting Torque M10	18 Nm ± 2 Nm
Insulating Tube:	Ceramic

Description

ZCASE® M10 32V automotive fuses take up minimal space while providing time-delayed/Slo-Blo® circuit protection similar to MEGA® 32V fuses. Typically used to protect starters, ZCASE M10 fuses with ampere ratings of 80 A to 250 A provide full wire protection. Use fuses rated 300–600 A only for short circuit protection.

Features & Benefits

- One-bolt connection
- Can mount on a battery post, starter, or busbar
- High-contrast ampere rating stamp aids identification
- 425 A fuse, 600 A fuse, and shunt offered in addition to fuses listed in ISO standard

Applications

- Commercial vehicles
- Buses
- Construction equipment
- Material handling equipment
- Agricultural machinery

Ordering Information

Part Number	Current Rating (A)	Package Size
3298XXX.ZXM10	80–600 & SHUNT	480

ZCASE® M10 Bolt Down Single Fuses

Rated 32V

Ratings

Part Number	Current Rating (A)	Test Cable Size (mm ²)	Typ. Voltage Drop (mV)	Typ. Cold Resistance (mΩ)	I ² t (A ² s)
3298080_	80	10	95	0.78	32 000
3298100_	100	16	80	0.57	23 200
3298125_	125	16	90	0.46	51 000
3298150_	150	25	78	0.34	81 600
3298175_	175	25	97	0.29	108 600
3298200_	200	35	94	0.26	126 400
3298225_	225	35	80	0.18	126 900
3298250_	250	50	82	0.17	160 900
3298300_ ²	300	35	28 ³	0.14	305 300
3298350_ ²	350	35	29 ³	0.10	583 900
3298400_ ²	400	50	27 ³	0.08	913 300
3298425_ ^{1 2}	425	50	27 ³	0.08	602 770
3298500_ ²	500	50	32 ³	0.08	1 250 000
3298600_ ^{1 2}	600	50	32 ³	0.05	3 140 000
3298900_ ¹	SHUNT	50	34	—	—

* Note 1: Not mentioned in ISO standards

* Note 2: Short circuit protector only

* Note 3: Voltage drop measurements for short circuit protectors taken at 50 % of rated current.

The typical I²t is an average value calculated from the breaking capacity tests by using the melting time before arcing occurs.

Dimensions

Dimensions in mm for reference only.
See outline drawing for dimensions and tolerances.

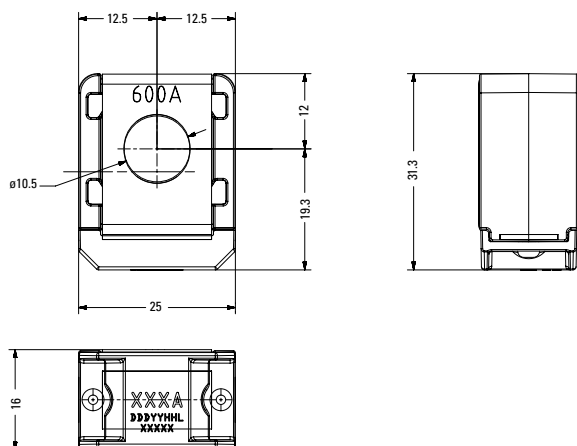

Assembly Components Sold Separately

Part No.	Description
902-192	Insulated M10 Bolt Required for Installation and Operation

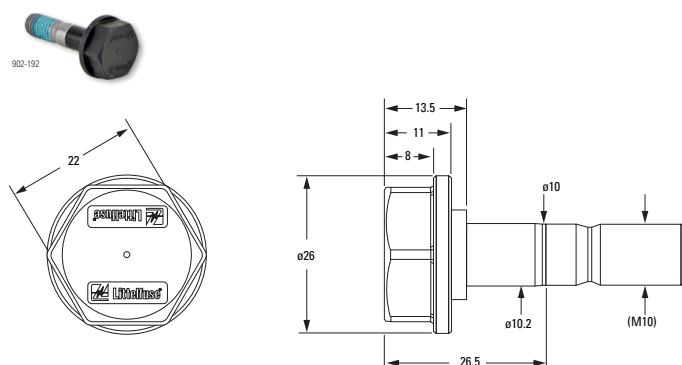

Please contact your Littelfuse representative for application support and information on mating hardware.

ZCASE® M10 Bolt Down Single Fuses

Rated 32V

Time-Current Characteristic Curves

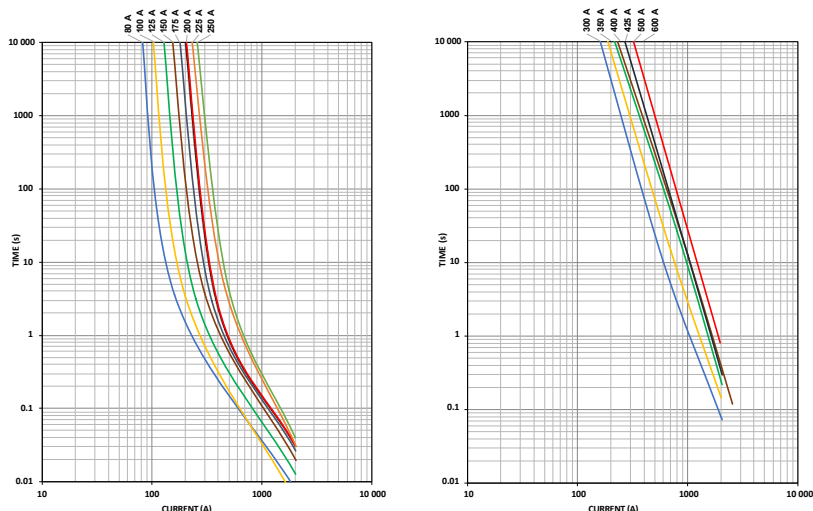

Time-Current Characteristics

% of Rating	Opening Time Min / Max (s)		
	40-250 A	300-500 A	600 A
50	- / -	14 400 / ∞	14 400 / ∞
100	14 400 / ∞	- / -	- / -
135	120 / 1800	- / -	- / -
200	1 / 15	1 / 40	1 / 40
350	0.3 / 5	0.3 / 5	0.3 / 5
500	- / -	- / -	0.1 / 1
600	0.1 / 1	0.1 / 1	- / -

Typical Derating of Fuse Melting Element

Temperature security margin is 20 %.
Please contact Littelfuse for details regarding derating test setup.

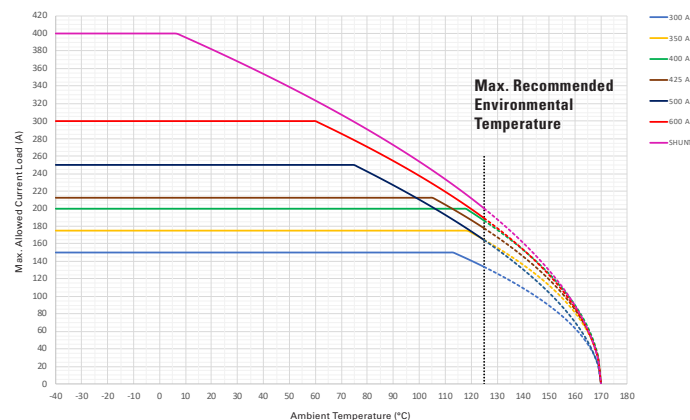
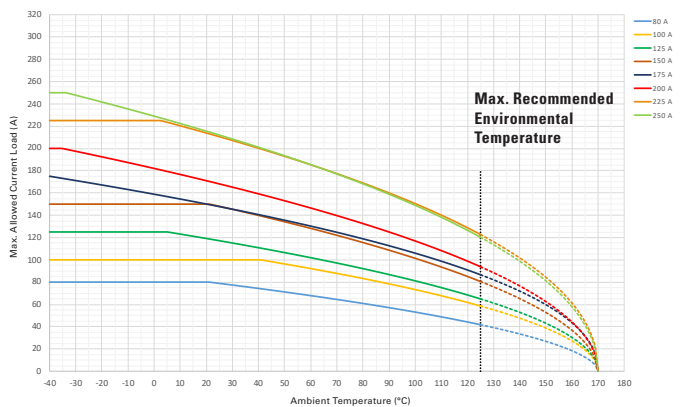

Derating curves may change depending on the final condition of the application (terminals' characteristics, wire size, etc.). Please ask Littelfuse for more information.

Temperature Table

	Max. allowed current load (A) at ambient temperature (typical derating)						
	-40 °C	0 °C	20 °C	65 °C	85 °C	110 °C	125 °C
80 A	80	80	80	66	59	49	42
100 A	100	100	100	90	81	68	59
125 A	125	125	119	100	89	75	65
150 A	150	150	150	125	112	94	81
175 A	175	159	150	128	116	99	87
200 A	200	182	171	143	129	108	94
225 A	225	225	214	181	165	140	123
250 A	250	229	215	181	164	138	120
300 A	150	150	150	150	150	150	134
350 A	175	175	175	175	175	175	164
400 A	200	200	200	200	200	200	186
425 A	213	213	213	213	213	205	178
500 A	250	250	250	250	235	193	164
600 A	300	300	300	293	263	219	189
SHUNT	400	400	382	316	282	234	200